

TEE FEMALE-FEMALE/FEMALE ADAPTER

R143.782.000

Series : TNC

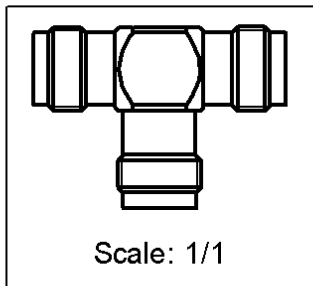
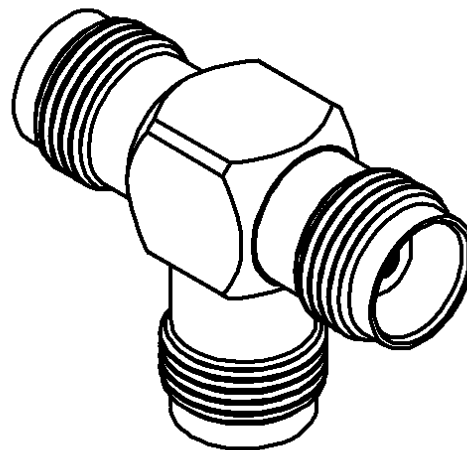
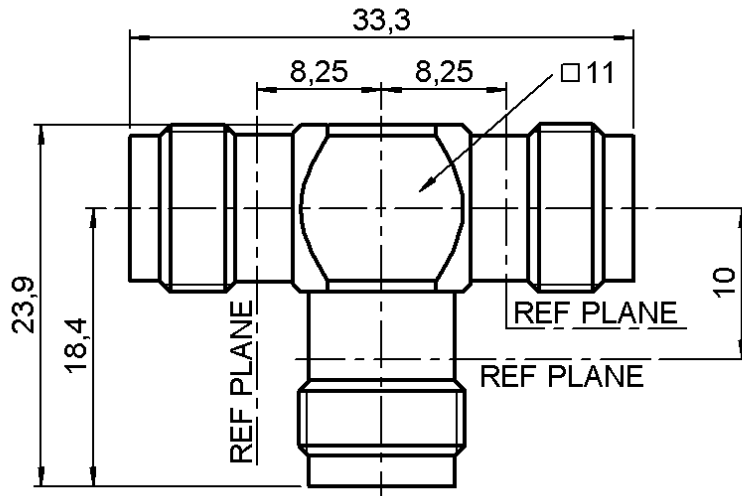

All dimensions are in mm.



COMPONENTS	MATERIALS	PLATINGS (µm)
BODY	BRASS	NICKEL 2
CENTER CONTACT	BERYLLIUM COPPER	GOLD 0.5 OVER NICKEL 2
OUTER CONTACT	-	-
INSULATOR	PTFE	-
GASKET	-	-
OTHERS PARTS	BRASS	NICKEL 2
-	-	-
-	-	-

Issue : 0226 N

In the effort to improve our products, we reserve the right to make changes judged to be necessary.



TEE FEMALE-FEMALE/FEMALE ADAPTER

R143.782.000

Series : TNC

PACKAGING

SPECIFICATION

Standard	Unit	Other
1	-	Contact us

QAE 06-02A - -

ELECTRICAL CHARACTERISTICS

ENVIRONMENTAL

Impedance **50** Ω
 Frequency **0-11** GHz
 VSWR **NA** + **0.000** x F(GHz) Maxi
 Insertion loss **0.07** √F(GHz) dB Maxi
 RF leakage - (**57** - F(GHz)) dB Maxi
 Voltage rating **500** Veff Maxi
 Dielectric withstanding voltage **1500** Veff mini
 Insulation resistance **5000** MΩ mini

Operating temperature **-65/+165** °C
 Hermetic seal **NA** Atm.cm3/s
 Panel leakage **NA**

OTHERS CHARACTERISTICS

Assembly instruction **NA**

Others :
-

MECHANICAL CHARACTERISTICS

Center contact retention
 Axial force – Mating end **18** N mini
 Axial force – Opposite end **18** N mini
 Torque **2.8** N.cm mini

Recommended torque
 Mating **NA** N.cm
 Panel nut **NA** N.cm

Mating life **500** Cycles mini
 Weight **17.000** g

Issue : 0226 N

In the effort to improve our products, we reserve the right to make changes judged to be necessary.

